



US006143075A

United States Patent [19]
Osbon

[11] **Patent Number:** **6,143,075**
[45] **Date of Patent:** **Nov. 7, 2000**

- [54] **PHOTO-FIBER LINK GLUE CONTROL SYSTEM**
- [76] Inventor: **Edward E Osbon**, 806 Guyton Rd., West Monroe, La. 71292
- [21] Appl. No.: **09/046,210**
- [22] Filed: **Mar. 23, 1998**
- [51] **Int. Cl.⁷** **B05B 5/00**
- [52] **U.S. Cl.** **118/302**; 118/696; 118/697; 118/698; 118/668; 118/669
- [58] **Field of Search** 118/696, 697, 118/698, 668, 669, 673, 672, 302
- [56] **References Cited**

U.S. PATENT DOCUMENTS

| | | | |
|-----------|---------|--------------|---------|
| 3,590,775 | 7/1971 | Barr | 118/667 |
| 4,031,854 | 6/1977 | Sprague, Jr. | 118/641 |
| 4,357,900 | 11/1982 | Buschor | 118/681 |
| 4,389,971 | 6/1983 | Schmidt | 118/669 |
| 4,527,510 | 7/1985 | Arndt | 118/669 |
| 5,217,745 | 6/1993 | Patel | 427/8 |

Primary Examiner—Francis J. Lorin

Attorney, Agent, or Firm—Michael I. Kroll

[57] **ABSTRACT**

A photo-fiber link glue control system (10) for accurately placing a pattern of glue on a sequential series of targets traveling with a conveyor (54) through the system (10). The system (10) includes an air reservoir (18) and a glue tank (24) for storing glue to be applied to the series of targets. A glue head (32) is connected to receive glue from the glue tank (24) for application to the series of targets. The lead and trailing edge of the target is detected by photo-eye sensors (44, 46) which generate a target position signal indicative of the sensed position. The pressure within the air reservoir (18) and glue tank (24) are monitored and a control device (36) stores a pattern in which the glue is to be applied to the target. Based upon the sensed pressure values, the sensed target position and the stored pattern, the control device (36) enables an air compressor (12) to receive air for delivery to the air reservoir (18) thus increasing the pressure therein and applying a pressure on the glue tank (24) causing glue to flow to the glue applicator (32) for placement on the target in accordance with the stored pattern.

19 Claims, 5 Drawing Sheets

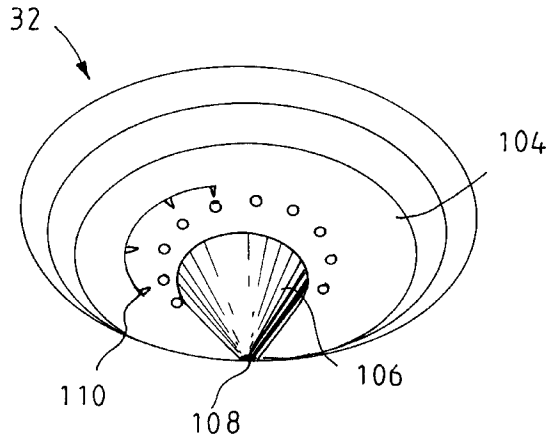
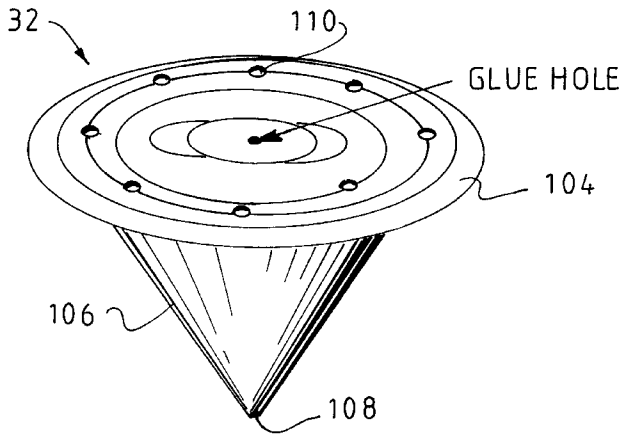

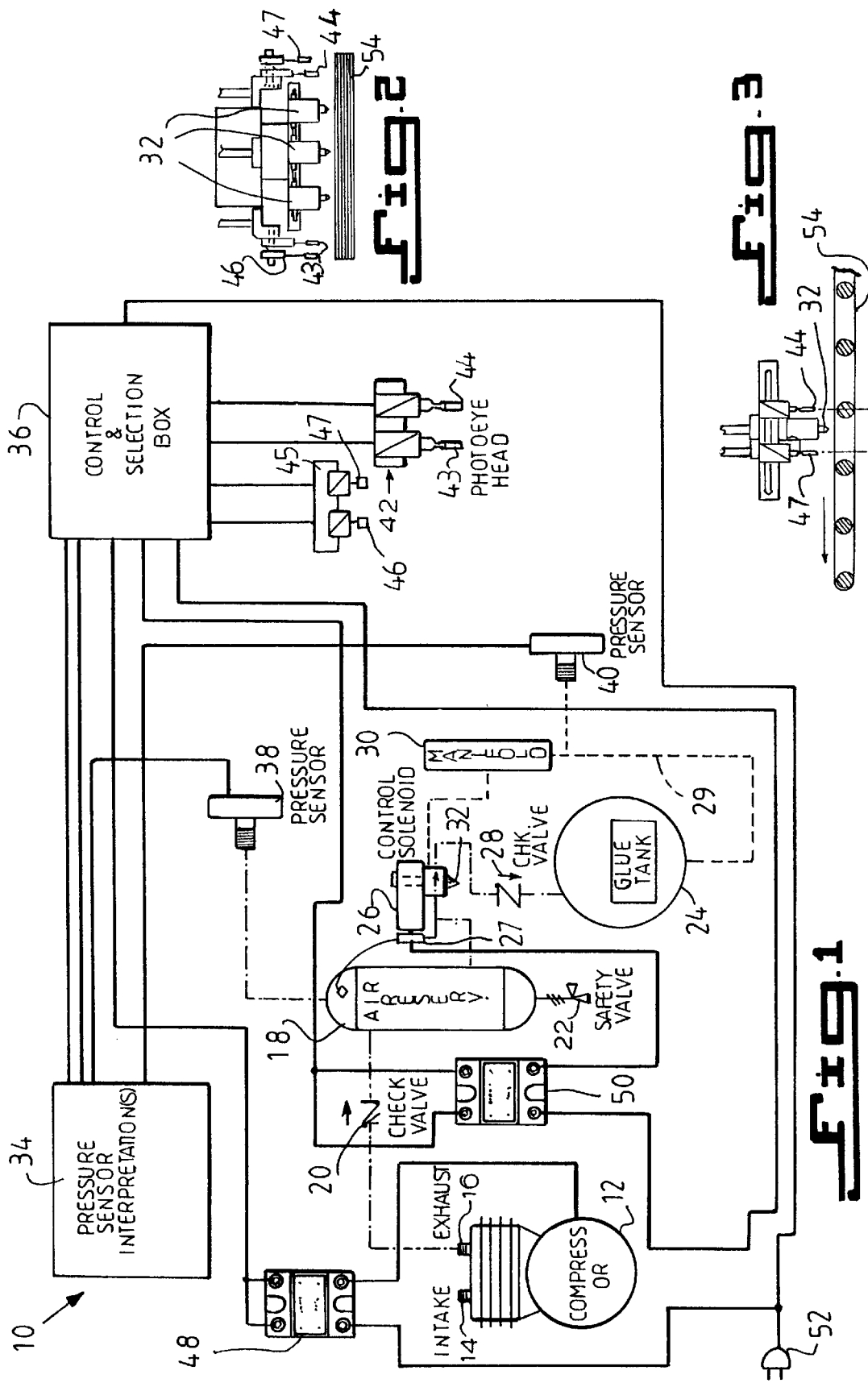

Fig. 4

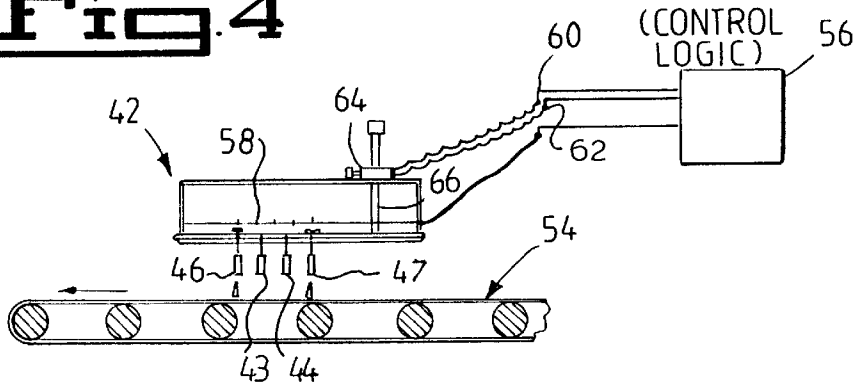
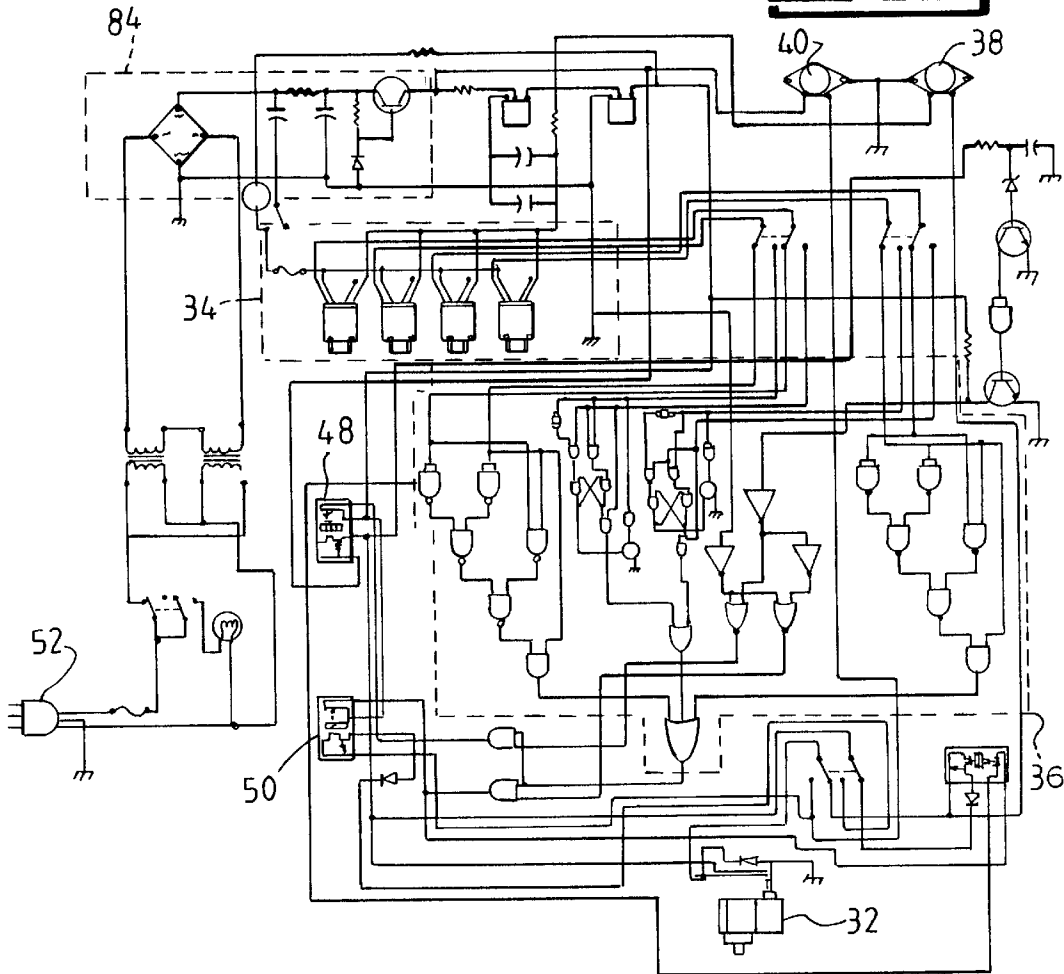
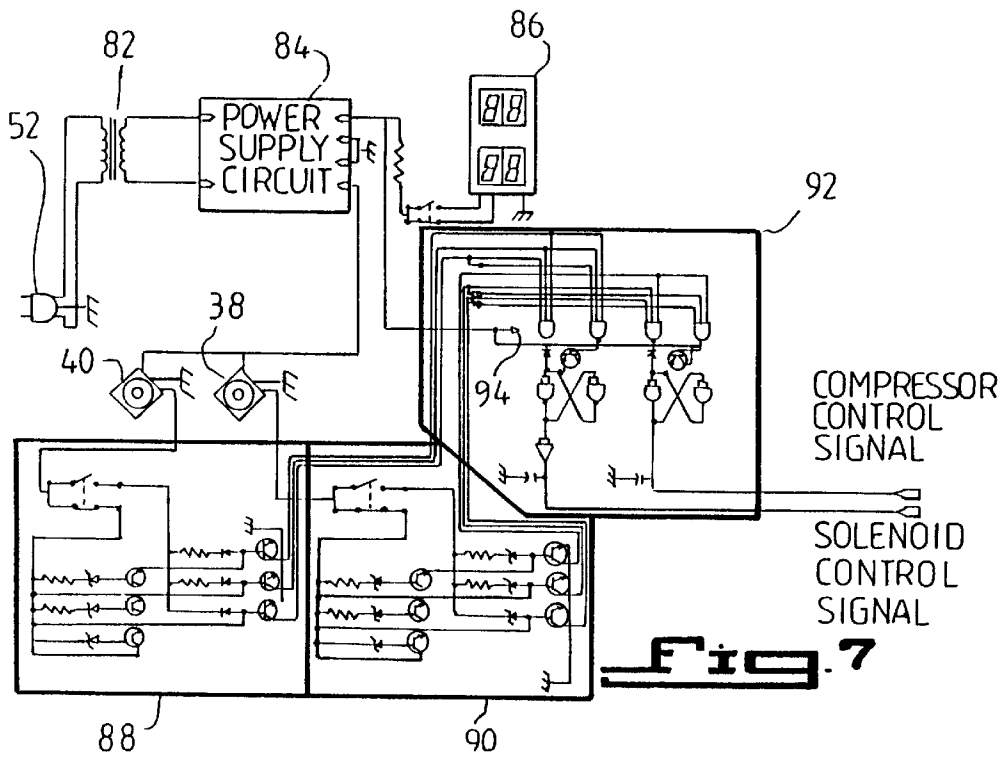
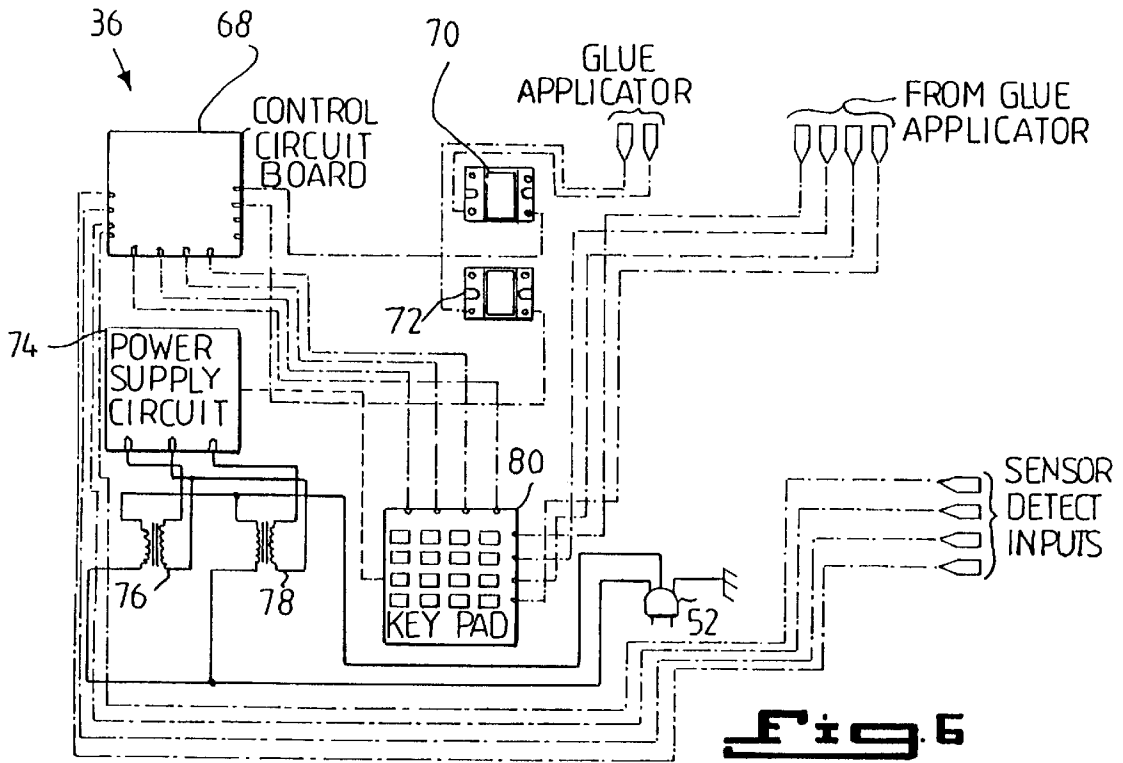

Fig. 5





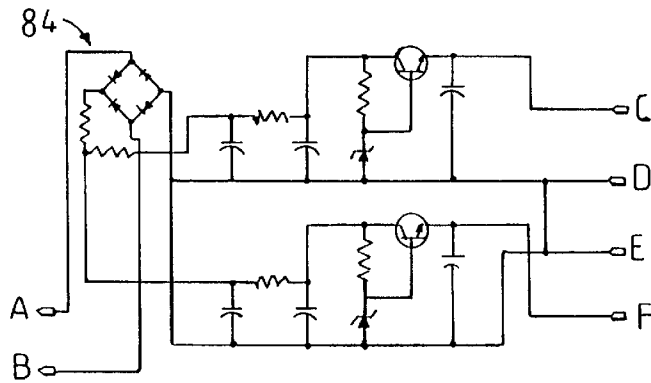

Fig. 8

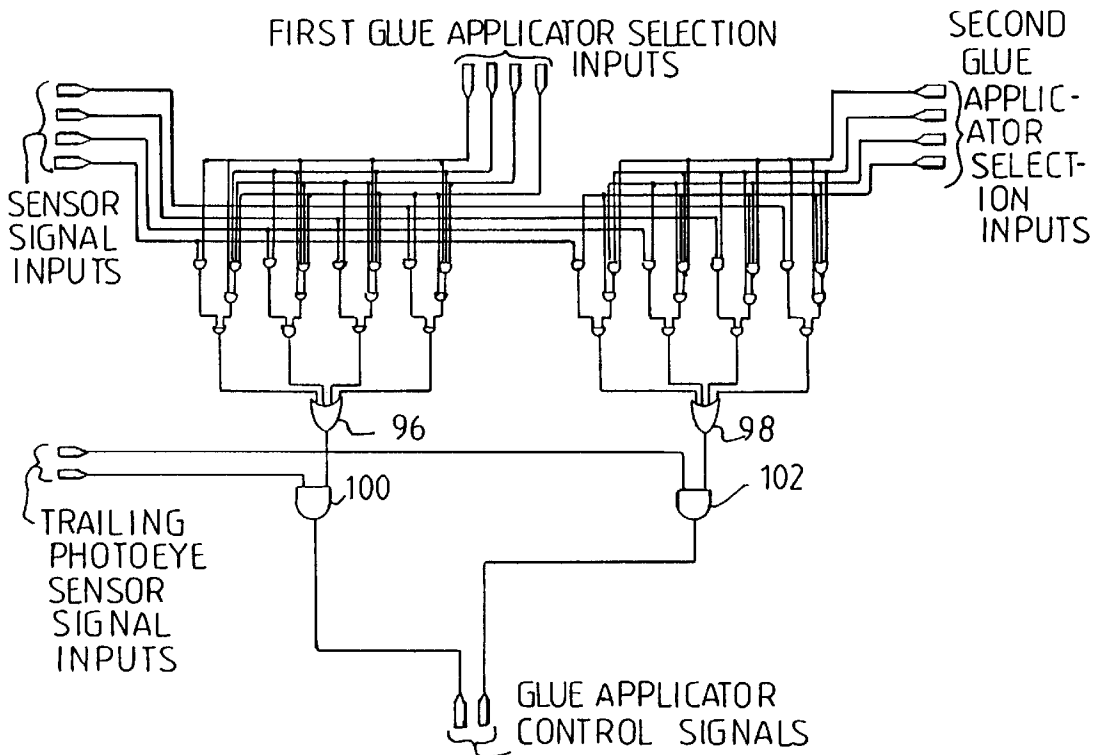

Fig. 9

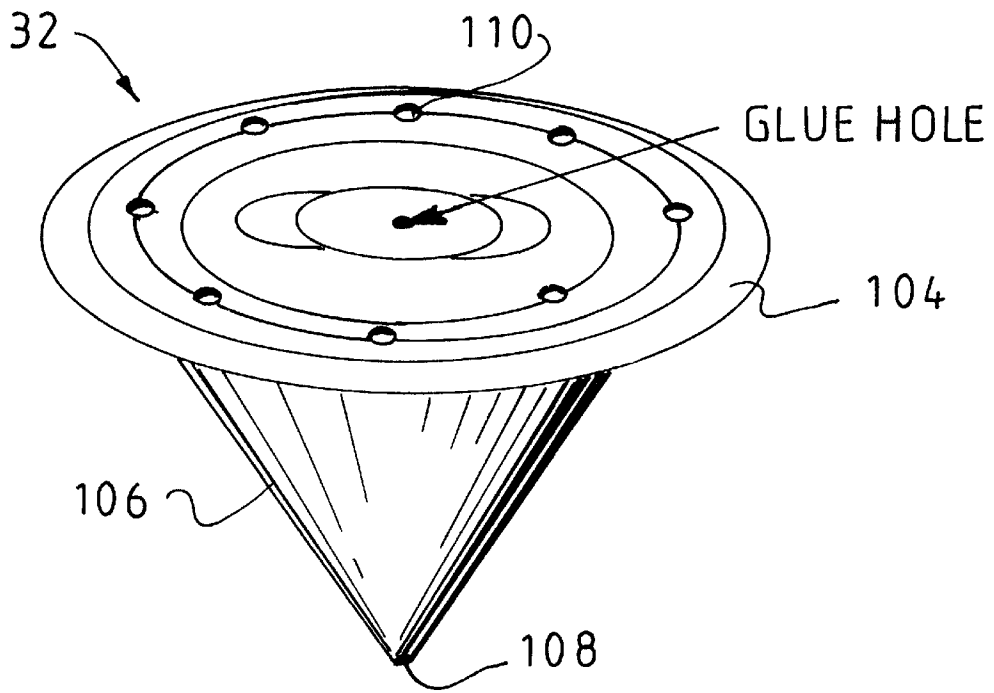

Fig. 10

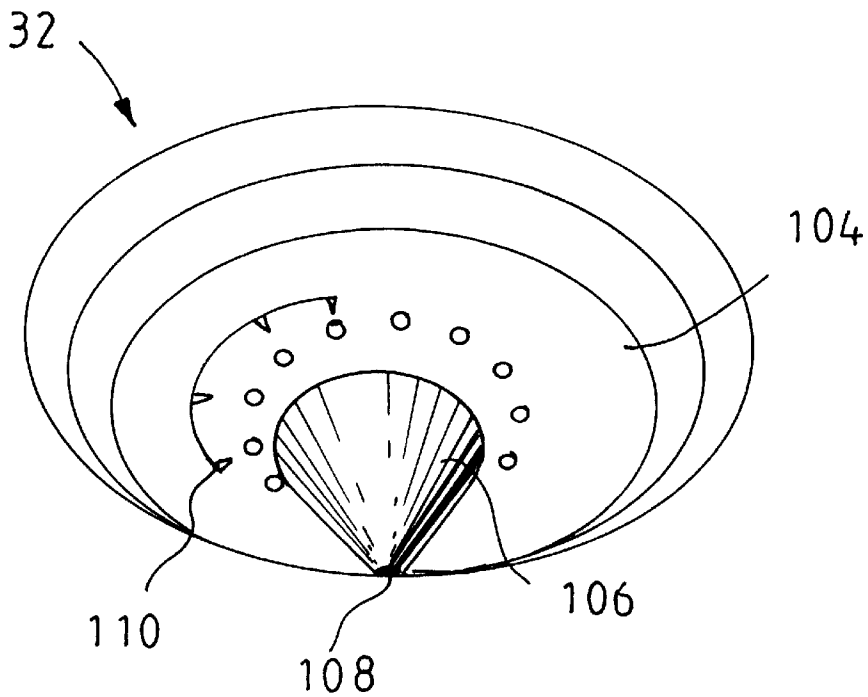

Fig. 11

PHOTO-FIBER LINK GLUE CONTROL SYSTEM

BACKGROUND OF THE INVENTION

1. Field of the Invention

The instant invention relates generally to systems for applying glue to a target and, more specifically, to a device for accurately placing a glue pattern on a plurality of successive targets and cleaning the glue tip of the applicator.

2. Description of the Prior Art

Numerous systems for placement of a glue pattern on a target are provided in the prior art. For example, U.S. Pat. Nos. 4,357,900; 4,389,971; 4,527,510; and 5,217,745 are all illustrative of such prior art. While these units may be suitable for the particular purpose to which they address, they would not be as suitable for the purposes of the present invention as heretofore described.

U.S. Pat. No. 4,357,900

Inventor: Karl Buschor

Issued: Nov. 9, 1982

An apparatus is disclosed for the automatic coating of articles. The apparatus has a spray device controlled by a programmed control device. A transport device transports the articles along a predetermined path to a coating position and then away therefrom after coating. A sensor monitors the position of the article and generates signals representative thereof, preferably generating one signal each time the article moves a predetermined distance (e.g. 2 cm.) along the path. A second sensor generates additional signals to the control device when an article passes a predetermined point, also indicating which of several types of articles has been detected. The control device controls the spraying process responsive to these signals. If desired, portions of the article that are moved sequentially into the coating position can be sprayed in different manners, e.g. with the spray devices positioned or oriented differently, or using different coating materials, etc. The control device is preferably reprogrammable.

U.S. Pat. No. 4,389,971

Inventor: Robert W. Schmidt

Issued: Jun. 28, 1983

A control for regulating the application of glue to a defined area of a moving paper board box blank includes a sensor for detecting the presence of the leading and trailing edges of a moving defined glue application area; a glue applicator spaced a fixed distance from the sensor; a pulse generator providing pulses indicative of movement of the application area; and counting means which are connected to the sensor, glue applicator and pulse generator. The sensor initiates a counting action at detection of the leading edge of a glue application after a predetermined number of counted pulses representative of the fixed distance between the sensor and glue applicator. The sensor initiates a second counting action at detection of the trailing edge of a glue application area and the counting means stops glue application after the same predetermined number of pulses representative of the sensor glue applicator fixed distance.

U.S. Pat. No. 4,527,510

Inventor: Raymond J. Arndt

Issued: Jul. 9, 1985

An improvement in apparatus for applying a coating to a surface of a moving work piece including a coating dis-

penser having at least one coating outlet for dispensing a stream of coating. A dispenser control unit is operatively coupled with the dispenser for normally initiating and terminating the dispensing of the stream of coating as predetermined parts of the work piece surface come into alignment with the coating outlet in response to the speed and position of the work piece surface. The invention provides a minimum coating control co-acting with the dispenser control unit for depositing a coating of a selectable minimum length to at least one portion of the work piece surface, said selectable minimum length being substantially less than that achievable by said dispenser control unit alone.

U.S. Pat. No. 5,217,745

Inventor: Baldev Patel

Issued: Jun. 8, 1993

Method and apparatus for applying a programmable pattern to a succession of moving objects, comprising a micro-processor for storing a user defined value representing the length of the pattern, a clock for generating a series of pulses and a photo-eye for detecting the presence of the succession of moving objects. Upon detecting the presence of a first one of the moving objects, a set-up mode gate is enabled for transmitting the clock pulses to a first divider circuit. The first divider circuit divides the number of transmitted clock pulses by the user defined value and in response generates and stores a first count value. Upon detecting the presence of subsequent moving objects, a run mode gate transmits successive predetermined numbers of clock pulses to a second divider circuit. The second divider circuit divides the successive predetermined numbers of clock pulses by a first count value and in response generates successive further count values with the user defined value and in the event the values are equal initiates application of the programmable pattern to the succession of objects, and in the event more than a predetermined number of the successive further count values are not equal to the user defined value the microprocessor re-initiates the setup mode procedure.

BRIEF SUMMARY OF THE INVENTION

The present invention is concerned with systems for placing glue on a target and, more specifically, to a system for accurately positioning glue patterns on a plurality of successive targets and cleaning the tip of the glue applicator.

A primary object of the present invention is to provide a photo-fiber link glue control system able to accurately position a glue bead on a target

An additional object of the present invention is to provide a photo-fiber link glue control system able to accurately place a glue bead on a number of successive targets passing beneath the glue applicator.

Another object of the present invention is to provide a photo-fiber link glue control system able to detect the initial presence of a target entering a glue placement area.

A further object of the present invention is to provide a photo-fiber link glue control system able to detect when the target has passed through the glue application area and causing operation of the glue applicator to cease.

A still further object of the present invention is to provide a photo-fiber link glue control system which is able to apply air from an air reservoir through the glue head when a target is not within the glue application area acting to clean the glue head of glue remaining thereon.

Another object of the present invention is to provide a photo-fiber link glue control system which is able to com-

pensate for changes in the speed of the conveyor or mechanical tolerances acting on the conveyor or target.

A further object of the present invention is to provide a photo-fiber link glue control system including a plurality of glue applicators able to apply a complex glue pattern on a target.

A still further object of the present invention is to provide a photo-fiber link glue control system able to regulate a line pressure of the glue applicator and provide each target with a substantially identical glue pattern.

A yet further object of the present invention is to provide a photo-fiber link glue control system including a control keypad for activating only one glue applicator based upon sensor signals detecting presence of the target thereby preventing human error.

A photo-fiber link glue control system for accurately placing a pattern of glue on a sequential series of targets traveling with a conveyor through the system is disclosed by the present invention. The system includes an air reservoir and a glue tank for storing glue to be applied to the series of targets. A glue head is connected to receive glue from the glue tank for application to the series of targets. The lead and trailing edge of the target is detected by photo-eye sensors which generate a target position signal indicative of the sensed position. The pressure within the air reservoir and glue tank are monitored and a control device stores a pattern in which the glue is to be applied to the target. Based upon the sensed pressure values, the sensed target position and the stored pattern, the control device enables a compressor device to receive air for delivery to the air reservoir thus increasing the pressure within the air reservoir and increase a pressure within the glue tank forcing glue to flow to the glue head for application on the target in accordance with the stored pattern.

The foregoing and other objects, advantages and characterizing features will become apparent from the following description of certain illustrative embodiments of the invention.

The novel features which are considered characteristic for the invention are set forth in the appended claims. The invention itself, however, both as to its construction and its method of operation, together with additional objects and advantages thereof, will be best understood from the following description of the specific embodiments when read and understood in connection with the accompanying drawings. Attention is called to the fact, however, that the drawings are illustrative only, and that changes may be made in the specific construction illustrated and described within the scope of the appended claims.

BRIEF DESCRIPTION OF THE DRAWING FIGURES

Various other objects, features and attendant advantages of the present invention will become more fully appreciated as the same becomes better understood when considered in conjunction with the accompanying drawings, in which like reference characters designate the same or similar parts throughout the several views.

FIG. 1 is a schematic diagram illustrating the photo-fiber link glue control system of the present invention without the conveyor system;

FIG. 2 is an front elevational view of the glue applicator and conveyor system of the photo-fiber link glue control system shown in FIG. 1;

FIG. 3 is a side elevational view of the glue applicator and conveyor system of the photo-fiber link glue control system shown in FIG. 1;

FIG. 4 is a schematic diagram of logic circuitry connected to the glue applicator system of the photo-fiber link glue control system of the present invention;

FIG. 5 is a logic diagram of the photo-fiber link glue control system illustrated in FIG. 1;

FIG. 6 is a schematic diagram of the control and selection box of the photo-fiber link glue control system of the present invention;

FIG. 7 is a logic diagram of the pressure sensor interpretation circuit of the photo-fiber link glue control system of the present invention;

FIG. 8 is a logic diagram of the power supply circuit of the photo-fiber link glue control system of the present invention;

FIG. 9 is a logic diagram of the control and switching logic circuit of the photo-fiber link glue control system of the present invention;

FIG. 10 is a top view of the glue head used to deposit glue by the photo-fiber link glue control system of the present invention; and

FIG. 11 is a side view of the glue head used to deposit glue by the photo-fiber link glue control system of the present invention.

DESCRIPTION OF THE REFERENCED NUMERALS

Turning now descriptively to the drawings, in which similar reference characters denote similar elements throughout the several views, the Figures illustrate the photo-fiber link glue control system of the present invention. With regard to the reference numerals used, the following numbering is used throughout the various drawing figures.

- 10 photo-fiber link glue control system of the present invention
- 12 compressor
- 14 compressor intake
- 16 compressor exhaust
- 18 air reservoir
- 20 first check valve
- 22 safety valve
- 24 glue tank
- 26 control solenoid
- 27 air valve
- 28 second check valve
- 29 glue line
- 30 manifold
- 32 glue head
- 34 pressure sensor interpretations circuit
- 36 control and selections box
- 38 first pressure sensor
- 40 second pressure sensor
- 42 glue photo-eye head
- 43 lead photo-eye sensor of glue photo-eye head
- 44 trailing photo-eye sensor of glue photo-eye head
- 45 air photo-eye head
- 46 lead photo-eye sensor of air photo-eye head
- 47 trailing photo-eye sensor of air photo-eye head
- 48 first solid state relay
- 50 second solid state relay
- 52 power supply
- 54 conveyor belt
- 56 control logic circuit
- 58 position indicators
- 60 input position signal line
- 62 output position control signal line
- 64 stepper motor

66 threaded shaft
 68 control circuit board
 70 third solid state relay
 72 fourth solid state relay
 74 power supply circuit
 76 first transformer
 78 second transformer
 80 keypad
 82 third transformer
 84 power supply circuit
 86 LED pressure display
 88 glue line pressure read section
 90 air tank pressure read section
 92 action section
 94 arrow indicating supply of power to gates in action section
 96 OR gate for first glue tank pressure control signal
 98 OR gate for second glue tank pressure control signal
 100 AND gate for first glue tank pressure control signal
 102 AND gate for second glue tank pressure control signal
 104 base section of glue head
 106 glue applicator section depending from base section
 108 glue hole
 110 air holes

DETAILED DESCRIPTION OF THE PREFERRED EMBODIMENT

Turning now descriptively to the drawings, in which similar reference characters denote similar elements throughout the several views, FIGS. 1 through 11 illustrate the photo-fiber link glue control system indicated generally by the numeral 10.

The photo-fiber link glue control system 10 includes a compressor 12 having an air intake port 14 and an air exhaust port 16. Air enters the compressor 12 through the air intake port 14 and exits through the air exhaust port 16 traveling to an air reservoir 18 via a check valve 20. The air reservoir 18 includes a safety valve 22 for regulating the pressure therein and is connected to a control solenoid 26 via an air valve 27. A glue tank 24 is connected to the air reservoir 18 via the air valve 27, the control solenoid 26 and a second check valve 28. Air is supplied from the air reservoir 18 through the control solenoid 26 and check valve 28 to the glue tank 24 to force glue out of the glue tank 24. The glue tank 24 supplies the glue forced therefrom through a glue line 29 and a manifold 30 to a glue head 32 for application to a target (not shown). The glue head 32 is connected to the control solenoid 26 and is also connected via the air valve 33 to the air reservoir 18. The glue head 32 is designed to allow the flow of both air and glue there-through as will be explained in more detail hereinafter.

The air pressure within the air reservoir 18 is monitored by a first pressure sensor 38 and the pressure within the glue tank 24 and glue line 29 is monitored by a second pressure sensor 40. The pressure values sensed by the first and second pressure sensors 38, 40 are transmitted to a pressure sensor interpretations circuit 34. Based upon the received pressure values, the pressure sensor interpretations circuit 34 detects pressure changes in the air reservoir 18 and glue tank 24 and transmits control signals indicative of such detected changes in pressure to a control and selection box 36. The control and selection box 36 acts to control the air pressure in the air reservoir 18 and the pressure in the glue tank 24. A rise in pressure in the glue tank 24 causes glue to be delivered through the glue line 29 to the glue head 32 for application to a target based upon a preprogrammed and defined pattern. The control and selection box 36 also acts to maintain a

pre-selected pressure in the air reservoir 18. Upon a detected change in the pressure in the air reservoir 18 or in the ratio between the air reservoir 18 and the glue tank 24 the control and selection box 36 acts to replenish the depleted air supply by controlling the compressor 12. As the pressure in the air reservoir 18 is typically much higher than that in the glue tank 24, the control solenoid 26 acts to expose the glue tank 24 to the air reservoir 18 as needed to maintain the pre-selected pressure ratio and pre-selected pressure in the glue line 29.

First and second solid state relays 48, 50 respectively, are both also connected to the control and selection box 36. The first solid state relay 48 is connected between the control and selection box 36, the compressor 12 and the power supply 52. The second solid state relay 50 is connected between the control solenoid 26 and the control and selection box 36. Based upon the signals received from the pressure sensor interpretations circuit 34, the control and selection box 36 is connected to activate the first and second solid state relays 48, 50 thereby controlling the pressure within both the air reservoir 18 and glue tank 24 and the application of glue by the glue head 32 to the target.

The control and selection box 36 is connected to a first glue photo-eye head 42 including a lead photo-eye sensor 43 and a trailing photo-eye sensor 44. The lead and trailing photo-eye sensors 43, 44 respectively detect the position of a target passing through a glue application area and transmit signals indicative of the target's position to the control and selection box 36. When signals indicating the target is positioned within the glue application area are transmitted by the first glue photo-eye head 42, the control and selection box 36 will control the application of glue to the target. The control and selection box 36 is also connected to a second air photo-eye head 45 including a lead photo-eye sensor 46 and a trailing photo-eye sensor 47. The lead and trailing photo-eye sensors 46, 47 respectively detect when a target has passed through the glue application area and transmits signal indicative of the absence of the target from the glue application area to the control and selection box 36. When signals indicating the target is not positioned within the glue application area are transmitted by the second air photo-eye head 45, the control and selection box 36 will prevent the application of glue through the glue head 32 and control the application of air through the glue head 32 thus acting to clean the glue head 32.

As illustrated in FIGS. 2 and 3, a conveyor belt 54 extends below the glue head 32 whereby glue exiting the glue head 32 will be positioned on a target traveling with the conveyor 54 and passing by the glue head 32. The glue head 32 is positioned between both the glue lead photo-eye sensor 43 and air lead photo-eye sensor 46 and the glue trailing photo-eye sensor 44 and air trailing photo-eye sensor 47. The glue lead and trailing photo-eye sensors 43 and 44 accurately determine the position of the target on the conveyor 54 as it passes through the glue application area. The air lead and trailing photo-eye sensors 46 and 47 determine when a target is not positioned within the glue application area, they detect the leaving and entering of the target from the glue application area. FIG. 2 shows an embodiment including three glue heads 32 for placing a pattern of glue on the target. The target is carried on the conveyor 54 so as to pass below the photo-eye heads 42 and 45 and the glue heads 32. As depicted in FIG. 3, the conveyor 54 and thus the target move from right to left.

A control logic circuit 56 may be connected to the glue and air photo-eye heads 42 and 45 as illustrated in FIG. 4. The glue and air photo-eye heads 42 and 45 each include a

plurality of adjustable position indicators **58** connected to the glue lead and trailing photo-eye sensors **43** and **44** and the air lead and trailing photo-eye sensors **46** and **47** for generating pulse signals indicating the position and aiding in the movement of the glue lead and trailing photo-eye sensors **43**, **44** and air lead and trailing photo-eye sensors **46**, **47**, respectively. The control logic circuit **56** controls movement of the position indicators **58** and thus movement of the glue lead and trailing photo-eye sensors **43**, **44** and air lead and trailing photo-eye sensors **46**, **47**, respectively, in response to receipt of the pulse signals from the position indicators **58**. Based upon increases and decreases in the speed of the conveyor **54**, the control logic circuit **56** sends signals to a stepper motor **64** via input and output control wires **60**, **62** respectively. The stepper motor **64** may be in the form of a threaded shaft assembly wherein the input and output control wires **60**, **62** act to turn the threaded shaft **66** in a clockwise or counter clockwise direction based upon the change in speed of the conveyor **54**. The turning of the threaded shaft **66** acts to move the glue lead and trailing photo-eye sensors **43**, **44** and air lead and trailing photo-eye sensors **46**, **47**, respectively, along the length of the conveyor **54**. Movement of the photo-eye sensors allows for detection of the target either earlier or later along its path through the glue application area. The turning signals are determined by comparing the speed of the conveyor **54** to the oscillations of a fixed oscillator (not shown) within the control logic circuit **56**.

FIG. **5** illustrates a logic diagram of the present invention showing the logical iterations performed by the photo-fiber link glue system **10** in greater detail. These iterations regulate the amount of glue applied by the glue head **32** to a target and detect the position of the target as it passes the glue head **32** for accurate placement of the glue. The pressure sensor interpretations circuit **34**, control and selection box **36** and power supply circuit **84** are discussed in more detail with reference to FIGS. **6**, **7**, and **8** respectively. FIG. **5** illustrates the interaction and connections between these components.

The control and selection box **36** is depicted in more detail in FIG. **6** and includes a keypad **66**. The keypad **66** is used to select a particular sensor for activating a corresponding glue applicator **32**. This allows only a single glue head applicator **32** to be operated at one time based upon the signals from a particular photo-eye sensor. Operation of any combination of sensor signals attempting to control a glue head applicator **32** is thus prohibited. The selections input to the keypad **66** are transmitted to and stored in a control circuit **68** for activating the appropriate glue head applicator **32** based upon input signals received from the glue lead and trailing photo-eye sensors **43** and **44**. Based upon the signals from one of the glue photo-eye sensors **43** or **44**, the control circuit board **68** delivers a signal to third and fourth solid state relays **70** and **72**, respectively, which are connected to enable the appropriate glue head applicator **32**. In combination with the control of the pressure in the glue tank **24**, glue may now be applied to the target. When a signal indicating a target has passed out of the glue application area is received from the air trailing air photo-eye sensor **47**, application of glue is prevented by the control and selection box **36** and air is caused to be delivered to the glue head applicators **32**. When a signal indicating a subsequent target has moved into the glue application area is received from the air leading photo-eye sensor **46**, delivery of air to the glue head applicators **32** is prevented and glue is allowed to pass to the glue head applicators **32** in accordance with the programmed glue pattern. The power source **52** is connected

to supply voltage to the control and selection box **36**. Voltage is fed to the keyboard **66** via a power supply circuit **74** and first and second transformers **76** and **78**, respectively. The keyboard **66** is also used to input the glue pattern to be placed on the targets for storage in the control and selection box **36**. Based upon the pattern input on the keyboard **66**, the control and selection box **36** activates the glue head applicators **32** to place the glue on the target in accordance therewith.

The matching of one glue head applicator to a respective photo-eye sensor signal is accomplished by the logic circuit illustrated in FIG. **9**. The sensor signals are combined in two groups of AND gates with different combinations of glue applicator selection symbols from the keypad **66**. The first group of AND gates receives selection signals for a first glue applicator and the second group of AND gates receives selection symbols for a second glue applicator. After passing through the sequence of AND gates the resultant signals for the first glue applicator are passed to a first OR gate **96** and the resultant signals for the second glue applicator are passed to a second OR gate **98**. The output of the OR gates **96** and **98** are each then fed with a signal from the trailing photo-eye sensor **46** to a respective AND gate **100**, **102**. The output of the AND gates **100** and **102** are transmitted to the glue applicators as control signals for applying glue to the target.

The pressure sensor interpretations circuit **34** is depicted in more detail in FIG. **7** and is connected to the power source **52** through a third transformer **82** and power supply circuit **84**. Pressure values from the air tank pressure sensor **38** and glue line pressure sensor **40** are received and analyzed to produce a compressor output signal and a control solenoid signal for output to the control and selection box **36** for ultimate control of the pressure within the air reservoir **18** and glue tank **24**. The pressure values received from the air reservoir **18** and glue line pressure sensors **38**, **40** are also displayed on an LED display **86**. The pressure sensor interpretations box **34** is divided into two sections a read section for determining the pressure sensed and an action section for acting on the compressor **12** and control solenoid **26** based upon the read values. The read section **88**, **90** is divided into two parts, a first part **88** for reading the glue line pressure value and a second part **90** for reading the air reservoir pressure value. The read values are fed into a sequence of logic gates in the action section **92** to produce control signals which will regulate the pressure of the glue line **29** and air reservoir **18**. Each logic gate is individually supplied with power at an appropriate pin as depicted by the arrow **94**.

The power supply circuit **84** for providing power to the read section **88**, **90** and action section **92** is illustrated in more detail by FIG. **8**. The inputs A, B and outputs C, D, E and F are identical to those of FIG. **7**. Inputs A and B are connected across the secondary winding of the third transformer **82** to receive power from the power supply **52**. Output C supplies power to the action section **92** and output E supplies power to the read section **88,90** of the pressure sensor interpretations circuit **34**. This is a standard known power supply for a micro-switch sensor and thus further discussion of such is not necessary.

A top and side view of the glue head **32** is illustrated in FIGS. **10** and **11**, respectively. As is seen from these figures, the glue head **32** includes a base section **104** and a glue applicator section **106** depending therefrom. Extending from the base section **104** and through the glue applicator section **106** is a glue hole **108** for transmission of the glue supplied by the glue tank **24** therethrough. Extending through the

base section **104** and surrounding the glue applicator section **106** are a plurality of air passages **110**. The air passages allow the air supplied by the air reservoir **18** to pass therethrough and act to clean the glue hole **108** when glue is prevented from being applied.

In operation, a glue pattern to be formed on a sequence of targets is input to the keyboard **66** and stored in the control and selection box **36**. This pattern will be accurately placed on each target passing on the conveyor **54** and through the glue application area. The keypad **66** is also used to input instructions associating each glue head applicator **32** with a particular sensor signal. Thus, only one glue head applicator **32** may be enabled at a single time and cannot be controlled by combinations of additional sensor signals.

The glue is stored in the glue tank **24** connected to the glue head **32** via the glue line **29**, manifold **30** and control solenoid **26**. The pressure in the glue tank **24** and thus the glue line **29** is controlled by an air compression system connected thereto. The pressure in both the air reservoir **18** and the glue tank **24** are constantly monitored by pressure sensors **38** and **40** and the monitored pressure values are transmitted to a pressure sensor interpretations circuit **34**. The pressure values are constantly displayed on a display unit **86** for visually monitoring the pressure values.

The pressure values are also delivered to the control and selection box **36**. Through the first and second solid state relays **48**, **50** the control and selection box **36** controls the compressor **12** to supply air via the exhaust **16** and check valve **20** to the air reservoir **18**. This acts to replenish the air within the air reservoir **18** and thus increase the pressure in the air reservoir **18** upon determination of a change in the air pressure. The first and second solid state relays **48**, **50** are controlled to equalize the pressure based upon the determination of a pressure change in either the air reservoir **18** or glue line **29** or to increase the pressure in the glue tank **24** causing glue to flow to the glue head **32**. Based upon the stored glue pattern and the detection of a target passing below the glue head **32**, the glue is deposited on the target. Air is also delivered from the air reservoir **18** directly to the glue head **32** when a target is not passing through the glue application area for use in cleaning the glue head **32**.

When a change in the pressure values from the pre-selected values in the air reservoir **18** and glue line **29** is detected, the first and second solid state relays **48** and **50** are activated. The first solid state relay **48** enables the compressor **12** to receive air for delivery to the air reservoir **18**. The second solid state relay **50** activates the control solenoid **26** to allow the glue tank **24** greater exposure to the air reservoir **18** and thus allow an increased amount of air to pass to the glue tank **24** increasing the pressure therein. The change in pressure in the air reservoir **18** due to the increased air flow through the compressor **12** and activation of the control solenoid **26** causes air to flow into the glue tank **24** via the control solenoid **26** and second check valve **28** thereby increasing the pressure in the glue tank **24**.

The position of the glue and air photo-eye sensors **42** and **45**, respectively, is controlled by the control logic circuit **56** based upon the speed of the conveyor **54**. The position of the glue photo-eye sensors **43** and **44** and the air photo-eye sensors **46** and **47** is determined by position indicators which transmit a signal indicative of the determined positions to the control logic circuit **56**. As the speed of the conveyor **54** changes the position of the photo-eye sensors must be adjusted to reflect and react to this change. Thus, the speed of the conveyor **54** is constantly monitored by the control logic circuit **56** and compared to the oscillations of a crystal

oscillator to determine if any changes have occurred. When a change in speed is detected, the control logic circuit **56** acts to control a threaded shaft assembly **64** to turn and adjust the position of the position indicators **58** and glue and air photo-eye sensors **43,44** and **46,47**, respectively, connected thereto. As a target travels with the conveyor **54**, the glue lead photo-eye sensor **43** detects its position on the conveyor **54** as the target enters the glue application area and transmits a signal to the control and selection box **36** indicating the position of the target.

Additional photo-eye sensors may be placed in other positions throughout the glue application area to detect when the target enters other positions and to more accurately determine the orientation of the target on the conveyor **54**. The detection of these criteria aid in accurately placing the glue pattern on the target. Additional glue heads **32** may also be positioned throughout the glue application area for producing a more complex glue pattern on the target. Each glue head **32** may be associated with a particular glue photo-eye sensor **43** or **44**. The keypad **66**, as previously discussed, is used to input instructions which correlate the glue heads **32** and glue and air photo-eye sensors. This correlation allows only a single glue head applicator **32** to be activated at any one time in response to a signal from a particular glue photo-eye sensor, canceling the operation of any combination of signals attempting to control a glue head applicator **32** with a plurality of sensor signals. The keypad **66** and control circuit board **68** activate the control relays **70**, **72** to enable the particular glue head applicator **32**. This feature eliminates the possibility of human error by prohibiting operation of more than one glue head applicator at a time and the possibility of signals from more than one sensor activating numerous glue head applicators or affecting the control of the single activated glue applicator.

The control and selection box **36** analyzes the position signals generated by the glue photo-eye sensors **43** and **44**. Based upon these signals and the stored glue pattern the first solid state relay **48** is enabled causing air to be received by the air reservoir **18** via the compressor **12**, thus increasing the pressure therein and the second solid state relay **50** is enabled causing the control solenoid **26** to increase the exposure of the glue tank **24** and glue line **29** to the air reservoir **18** thereby increasing the pressure therein and causing glue to flow through the glue line **29**. This causes a glue bead to be applied to the target at the desired position or positions. As the target passes through the glue application area, glue is placed thereon in accordance with the stored glue pattern using the above described method. Upon detecting the passage of the trailing edge of the target by the glue and air trailing photo-eye sensors **44** and **47**, respectively, operation of the glue head applicators **32** is ceased thereby establishing a definite distance between the final glue bead placed on the target and the trailing edge of the target. At this time air is also caused to be supplied by the air reservoir **18** directly to the glue head **32**. The air will be caused to flow through the air passages **110** in the base section **104** of the glue head **32** acting to clean glue remaining on the glue head **32** from the glue head **32** and glue passage **108**.

When the glue and air leading edge sensors **43** and **46**, respectively, detect a subsequent target entering the glue application area, the air supplied from the air reservoir directly to the glue head **32** is ceased and enabling the glue head applicators **32** allowing glue to once again flow through the glue head **32**. Application of glue to the target is then repeated in accordance with the programmed glue pattern. By detecting the leading and trailing edges of the

target in this manner, it is possible to create the same glue pattern on subsequent targets passing through the glue area while accounting for the speed of the conveyor, placement of the target on the conveyor and other mechanical tolerances. It is also possible to prevent glue from being deposited on the conveyor belt **54** and continually clean glue remaining on the glue head **32** therefrom.

It will be understood that each of the elements described above, or two or more together, may also find a useful application in other types of applications differing from the type described above.

While the invention has been illustrated and described as shown in the drawings, it is not intended to be limited to the details shown, since it will be understood that various omissions, modifications, substitutions and changes in the forms and details of the formulation illustrated and in its operation can be made by those skilled in the art without departing in any way from the spirit of the present invention.

Without further analysis, the foregoing will so fully reveal the gist of the present invention that others can, by applying current knowledge, readily adapt it for various applications without omitting features that, from the standpoint of prior art, fairly constitute essential characteristics of this invention.

What is claimed is:

1. A photo-fiber link glue control system for accurately placing a pattern of glue on a sequential series of targets, each target having a lead and trailing edge, traveling with a conveyor through said system, said photo-fiber link glue control system comprising:

- a) air compression means;
- b) glue supply means connected to said air compression means for storing glue to be applied to the series of targets;
- c) glue head means for receiving glue from said glue supply means and applying the glue to the series of targets;
- d) first photo-eye sensor means for detecting the lead and trailing edge of the target and generating a target position signal based upon the detection;
- e) pressure sensor means for sensing a pressure within said air compression means and glue supply means and generating a pressure signal indicative of the sensed pressures;
- f) control means for storing a pattern for the application of glue to the target, said control means being connected to receive said position signal from said first photo-eye sensor and said pressure signal from said pressure sensor means, wherein said control means determines a position of the target on the conveyor based upon the position signal and controls said pressure within said air compression means to supply air to said glue supply means thereby increasing pressure within said glue supply means and causing glue to flow from said glue supply means to said glue head means for placement on the target in accordance with the stored pattern and said determined position of said target;
- g) a second photo-eye sensor means connected to said control means for detecting the trailing and leading edges of the target for controlling the application of air through said glue head means to clean said glue head means when the target is not positioned in the glue application area and generating a glue prevention signal to prevent glue from being delivered to said glue head means upon receipt of said glue prevention signal.

2. The photo-fiber link glue control system as recited in claim **1**, wherein said glue head means is also connected to said air reservoir and said control means causes air to be delivered directly to said glue head means upon receipt of said glue prevention signal.

3. The photo-fiber link glue control system as recited in claim **2**, wherein said second photo-eye sensor means is able to detect a subsequent target entering said glue application area and generating a glue application signal upon detecting the subsequent target entering the glue application area, wherein said control means allows glue to again be delivered to said glue head and prevents air from being delivered to said glue head means upon receipt of said glue application signal.

4. The photo-fiber link glue control system as recited in claim **1**, wherein said air compression means includes:

- a) an air compressor having an air intake valve for receiving air and an air exhaust valve; and
- b) an air reservoir connected to said air exhaust valve for receiving air from said air compressor thereby increasing air pressure within said air reservoir upon receipt of said control signal by said compressor.

5. The photo-fiber link glue control system as recited in claim **4**, wherein said system further comprises:

- a) a control solenoid connected between said air reservoir and said glue supply means;
- b) a first solid state relay connected between said control means and said air compressor for receiving said control signal from said control means and activating said air compressor to receive air through said air intake valve upon receipt of said control signal; and
- c) a second solid state relay connected between said control means and said control solenoid for receiving said control signal from said control means and activating said control solenoid to expose said glue supply means to said air reservoir and thereby increase pressure in said glue supply means based upon said control signal.

6. The photo-fiber link glue control system as recited in claim **5**, further comprising a pressure sensor interpretations circuit connected to receive said pressure signals from said pressure sensing means, for analyzing said pressure signals to determine if said pressure in said air reservoir and said glue supply means are equal to a predetermined value and signaling said control means to activate said air compressor and control solenoid based upon a determination said pressure signals is different from said predetermined value.

7. The photo-fiber link glue control system as recited in claim **4**, wherein said pressure sensor means includes a first pressure sensor connected to sense said pressure in said air reservoir and a second pressure sensor connected to sense said pressure in said glue supply means.

8. The photo-fiber link glue control system as recited in claim **2**, wherein said second photo-eye sensor means includes a lead photo-eye sensor for detecting the leading edge of a target entering the glue area and a trailing edge photo-eye sensor for detecting the trailing edge of the target.

9. The photo-fiber link glue control system as recited in claim **8**, wherein said glue head means includes a plurality of glue heads for producing a complex glue pattern on the targets.

10. The photo-fiber link glue control system as recited in claim **1**, wherein said control means includes a keypad for use in externally inputting a glue pattern for storage in said control means.

11. The photo-fiber link glue control system as recited in claim **10**, wherein said first photo-eye sensor means includes

13

a plurality of photo-eye sensors each connected to said control means for sensing a position of the target and transmitting a signal indicative of the sensed position to said control means.

12. The photo-fiber link glue control system as recited in claim **11**, wherein each of said plurality of glue applicators is enabled to apply glue to the target based upon a respective first photo-eye sensor signal, each of said plurality of glue applicators and respective first photo-eye sensor signals being correlated based upon instructions input to said keypad.

13. The photo-fiber link glue control system as recited in claim **12**, wherein, upon activation of a first one of said plurality of glue heads, said control means disables all remaining glue heads.

14. The photo-fiber link glue control system as recited in claim **13**, wherein said trailing edge photo-eye sensor of said first photo-eye sensor determines a distance between a glue bead placed on the target and the trailing edge of the target.

15. The photo-fiber link glue control system as recited in claim **14**, wherein said trailing photo-eye sensor of said first photo-eye sensor disables said glue head means upon detection of the trailing edge of the target.

16. The photo-fiber link glue control system as recited in claim **15**, wherein said lead photo-eye sensor of said first photo-eye sensor enables said glue head means upon detection of the lead edge of the target.

14

17. The photo-fiber link glue control system as recited in claim **16**, wherein said pressure sensor interpretations circuit further includes an LED display for visually displaying said pressure signals.

18. The photo-fiber link glue control system as recited in claim **17**, further comprising a position control device for detecting a position of said first and second photo-eye sensor means and changes in a speed of the conveyor and adjusting said first and second photo-eye sensor means based upon a detection of a change in the speed of the conveyor.

19. The photo-fiber link glue control system as recited in claim **18**, wherein said position control device includes:

- a) position indicators connected to said photo-eye sensor means for detecting a position of said photo-eye sensor means;
- b) analysis means for analyzing said position detected by said position indicators and said speed of said conveyor and producing a control signal based upon said analysis; and
- c) stepper motor means connected between said analysis means and said photo-eye sensor means for adjusting a position of said photo-eye sensor means upon receipt of said control signal from said analysis means.

* * * * *